

NOTE:

1.MATERIAL SPECIFICATION:

- 1.HOUSING: LCP/PA46,UL94 V-0.
- 2.CONTACTS: C2680/C5191
- 3.SHELL: SUS304/SUS201

2.PLATING SPECIFICATION:

- 2-1.CONTACTS:
Ni 50u" MIN. UNDER PLATED OVER ALL.
Au PLATED ON THE FUNCTIONAL AREA OF CONTACT.
(GOLD PLATING THICKNESS FOLLOW THE P/N)
GOLD FLASH PLATING ON SOLDER AREA

2-2.SHELL:

- Ni 30u" MIN. UNDER PLATED OVER ALL.

3.MECHANICAL PERFORMANCE,

- 3-1.INSERTION FORCE: 0.5~2.0kgf.
- 3-2.REMOVAL FORCE: 0.8kgf~2.0kgf.
- 3-3.DURABILITY: 3000 CYCLES.

4.ELECTRICAL PERFORMANCE,

- 4-1. CURRENT RATING: 2.0A
VOLTAGE RATING: 5.0V
- 4-2.INSULATION RESISTANCE: 100MΩ MIN
- 4-3.DIELECTRIC WITHSTAND VOLTAGE, AC 100V FOR 1 MINUTE.
- 4-4.LOW CONTACT RESISTANCE: INITIAL 40MΩ / AFTER 50MΩ

5. ENVIRONMENTAL PERFORMANCE:

- OPERATING TEMPERATURE: -30°C~+80°C.

6.IR REFLOW:

- THE PEAK TEMPERATURE ON THE BOARD SHALL BE MAINTAINED FOR 10 SECONDS AT 260°C.

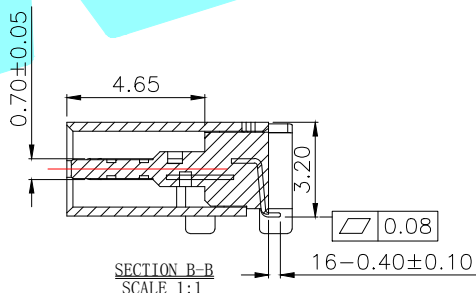
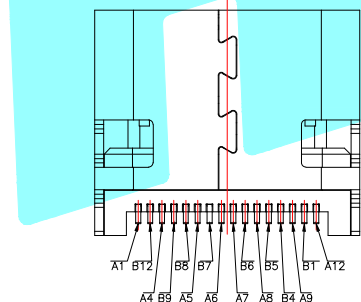
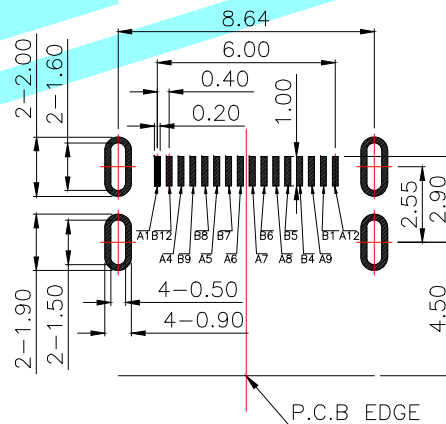
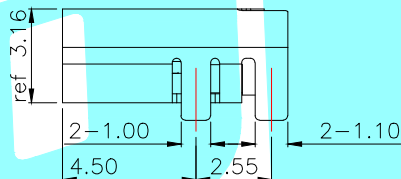
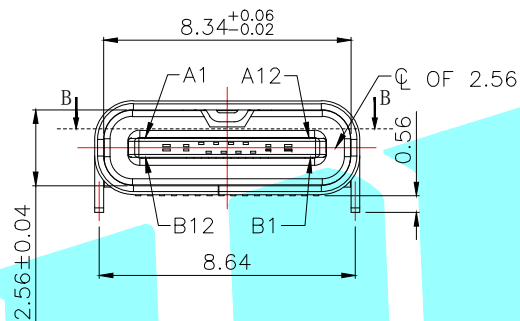

RECOMMEND P.C.B LAYOUT (COMPONENT SIDE)
TOLERANCE FOR PCB LAYOUT IS ± 0.05

A1	GND	B12	GND
A4	VBUS	B9	VBUS
A5	CC1	B8	SBU2
A6	DP1	B7	DN2
A7	DN1	B6	DP2
A8	SBU1	B5	CC2
A9	VBUS	B4	VBUS
A12	GND	B1	GND
PIN	SIGNAL NAME	PIN	SIGNAL NAME

APPROVALS		DATE	HRO 韓源® ELECTRONICS CO.,LTD			
DRAWN	LIUCAN	2021.3.6	TITLE:	插脚间距 2.55MM		
CHECKED			PART NO.	TYPE-C-31-M-08A		
APPROVALS			UNIT: mm	SCALE: 1:1		
TOLERANCES ARE	30~以上	±0.30	ANGLE	PROJ:		
	10~30	±0.25				
	5~10	±0.20				
	~ 5	±0.15	±2'	DRAWING NO.		
ECN NO.	REV.	DATE.	CHANGE.	CHECK.	APPRO.	SHEET 1 OF 1

ECN NO.	REV.	DATE.	DESCRIPTION.	CHANGE.	CHECK.	APPRO.
	A		NEW			

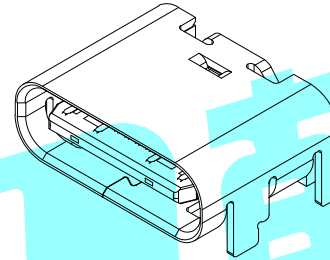
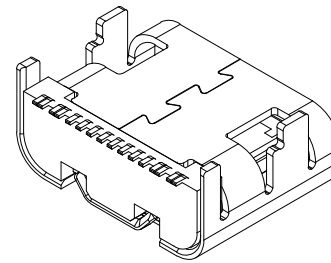
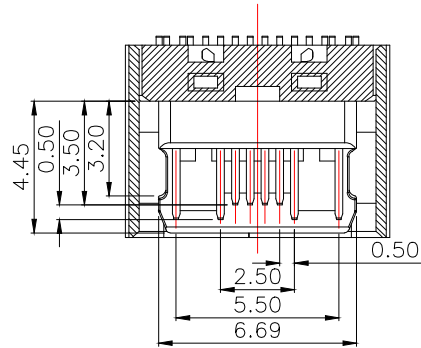
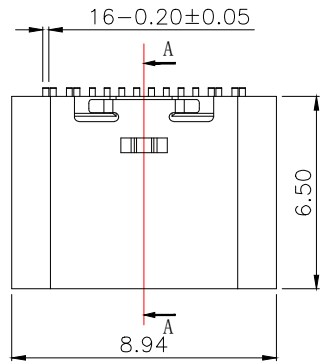

NOTE:

- 1.MATERIAL SPECIFICATION:
 - 1.HOUSING: HIGH TEMPERATURE RESISTANT PLASTIC,UL94 V-0.
 - 2.CONTACTS: COPPER ALLOY
 - 3.MID PLATE: STAINLESS STEEL
- 2.PLATING SPECIFICATION:
 - 2-1.CONTACTS:
 - Ni 50u" MIN. UNDER PLATED OVER ALL.
 - Au PLATED ON THE FUNCTIONAL AREA OF CONTACT.
 - (GOLD PLATING THICKNESS FOLLOW THE P/N)
 - GOLD FLASH PLATING ON SOLDER AREA
 - 2-2.FRONT SHELL:
 - Ni 30u" MIN. UNDER PLATED OVER ALL.
- 3.MECHANICAL PERFORMANCE,
 - 3-1.INSERTION FORCE: 0.5~2.0kgf.
 - 3-2.REMOVAL FORCE: 0.8kgf~2.0kgf.
 - 3-3.DURABILITY: 10000 CYCLES.
- 4.ELECTRICAL PERFORMANCE,
 - 4-1. CURRENT RATING: 5A
VOLTAGE RATING: 20V
 - 4-2.INSULATION RESISTANCE: 100MΩ MIN
 - 4-3.DIELECTRIC WITHSTAND VOLTAGE,AC 100V FOR 1 MINUTE.
5. ENVIRONMENTAL PERFORMANCE:
 - OPERATING TEMPERATURE: -30°C~+80°C.
- 6.IR REFLOW:
 - THE PEAK TEMPERATURE ON THE BOARD SHALL BE MAINTAINED FOR 10 SECONDS AT 260°C.

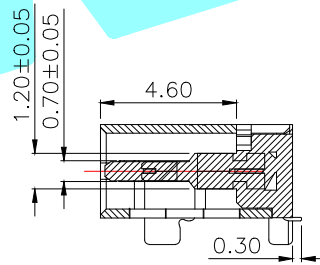
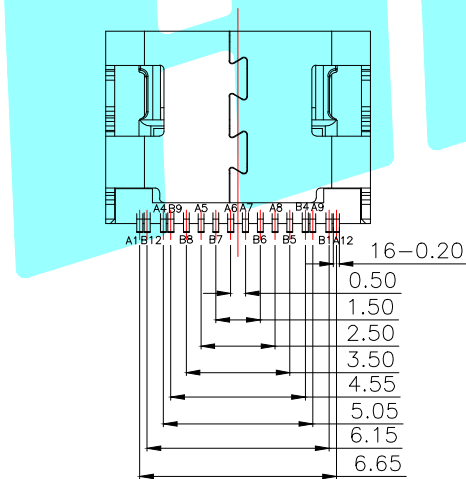
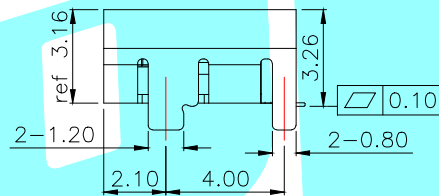
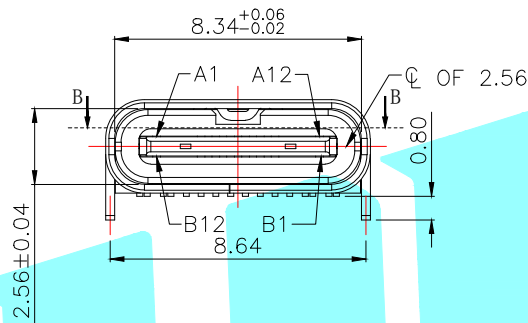

SECTION B-B
SCALE 1:1

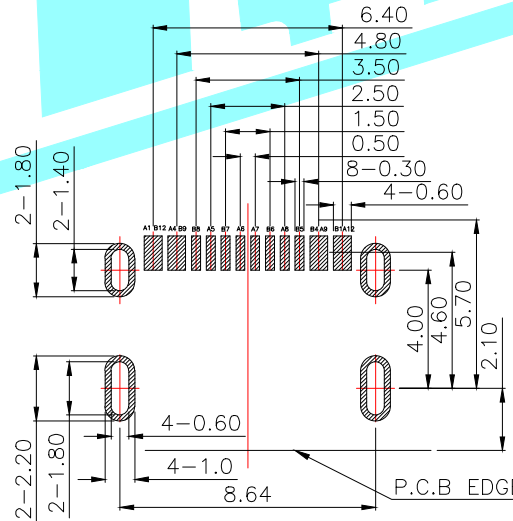

RECOMMEND P.C.B LAYOUT (COMPONENT SIDE)
TOLERANCE FOR PCB LAYOUT IS ± 0.05

A1	GND	B12	GND
A4	VBUS	B9	VBUS
A5	CC1	B8	SBU2
A6	DP1	B7	DN2
A7	DN1	B6	DP2
A8	SBU1	B5	CC2
A9	VBUS	B4	VBUS
A12	GND	B1	GND
PIN	SIGNAL NAME	PIN	SIGNAL NAME

APPROVALS		DATE	HRO 韩源® ELECTRONICS CO.,LTD		
DRAWN	LIUCAN	2021.3.6	TITLE:	插脚间距4.0MM	
CHECKED			PART NO.	TYPE-C-31-M-08B	
APPROVALS			UNIT: mm	SCALE: 1:1	PROJ:
TOLERANCES ARE	30~以上	±0.30	ANGLE	DRAWING NO.	SHEET 1 OF 1
	10~30	±0.25			
	5~10	±0.20			
	~ 5	±0.15	±2°		

ECN NO.	REV.	DATE.	DESCRIPTION.	CHANGE.	CHECK.	APPRO.
	A		NEW			