

1. 额定电流: Current Rating
1.5A/contact terminal

2. 额定电压: Voltage Rating
30V DC

3. 插拔力: Connector Mate and Unmate Force
Mate force: 3.57kgf(MAX)
Unmate force: 1.02kgf(MIN)

③	Base	—	1	NYLON	—	—
②	Terminal	—	4	Copper Alloy	Au/Sn Plated	—
①	Housing	—	1	Copper Alloy	Sn/Ni Plated	—
ITEM	PART NAME	TER'NO.	QTY.	MATERIAL	FINISHING	REMARK

APPROVALS		DATE		 ELECTRONICS CO.,LTD		
DRAWN	LIUCAN	2021.5.15				
CHECKED				TITLE:	USB CONNECTOR	
APPROVALS				PART NO.	U-A-24DD-Y-15	
TOLERANCES ARE	30~以上	±0.30	ANGLE	UNIT: mm	SCALE: 1:1	PROJ:
	10~30	±0.25				
	5~10	±0.20	±2'	DRAWING NO.		SHEET 1 OF 1
	~ 5	±0.15				

—	A	—	NEW	—	—	—
ECN NO.	REV.	DATE.	DESCRIPTION.	CHANGE.	CHECK.	APPRO.

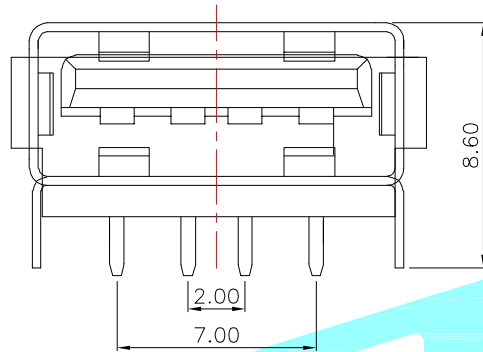
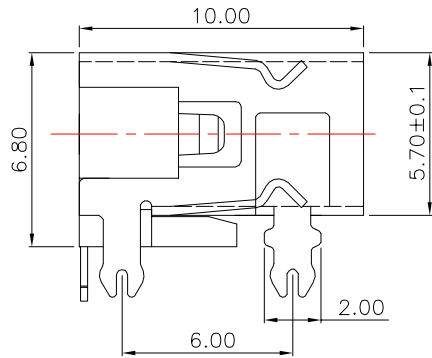

NOTES:

- 1.ELECTRICAL PERFORMANCE,
 CONTACT RESISTANCE:30MΩ MAX
 CONTACT CURRENT RATING:1.5 A
 DIELECTRIC WITHSTAND VOLTAGE,500V R.M.S
 INSULATION RESISTANCE: 1000MΩ MIN
- 2.MECHANICAL PERFORMANCE,
 INSERTION FORCE: 3.57kgf Max
 REMOVAL FORCE: 1.02kgf Min
 DURABILITY: 5000 CYCLES.

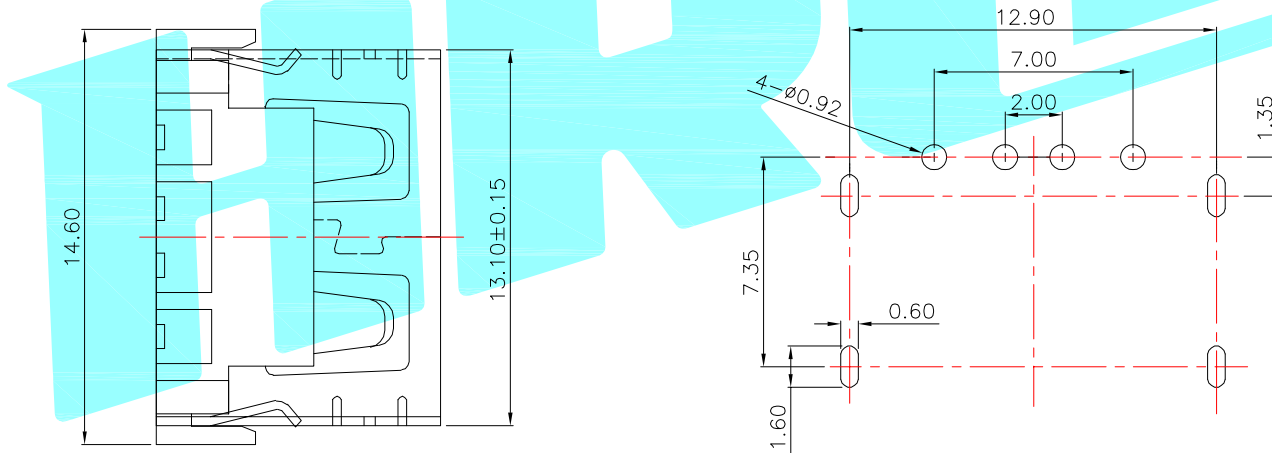

RECOMMEND P.C.B LAYOUT(COMPONENT SIDE)
 TOLERANCE FOR PCB LAYOUT IS ± 0.05

③	Shell	—	1	Copper Alloy	Sn Plated	—
②	Terminal	—	4	Copper Alloy	Au/Sn Plated	—
①	Housing	—	1	LCP	Black	—
ITEM	PART NAME	TER'NO.	QTY.	MATERIAL	FINISHING	REMARK

APPROVALS		DATE		ELECTRONICS CO.,LTD			
DRAWN	LIUCAN	2021.11.11					
CHECKED				TITLE: USB CONNECTOR			
APPROVALS				PART NO. U-A-24DD-W-19			
TOLERANCES ARE		30~以上	±0.30	ANGLE	UNIT: mm	SCALE: 1:1	PROJ:
		10~30	±0.25				
		5~10	±0.20				
		~ 5	±0.15				
				±2'	DRAWING NO.		SHEET 1 OF 1

_____	A	_____	NEW	_____	_____	_____
ECN NO.	REV.	DATE.	DESCRIPTION.	CHANGE.	CHECK.	APPRO.